

# ELECTRO-TYFON<sup>®</sup> MT 150/130

For vessels of 75 m to 200 m in length

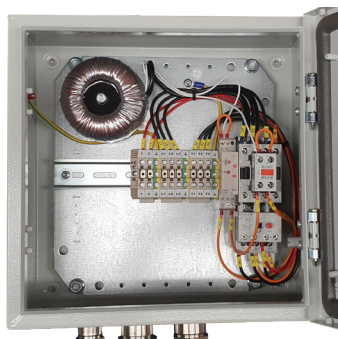

**Contactor Unit TK 80**  
See separate leaflet KSM742

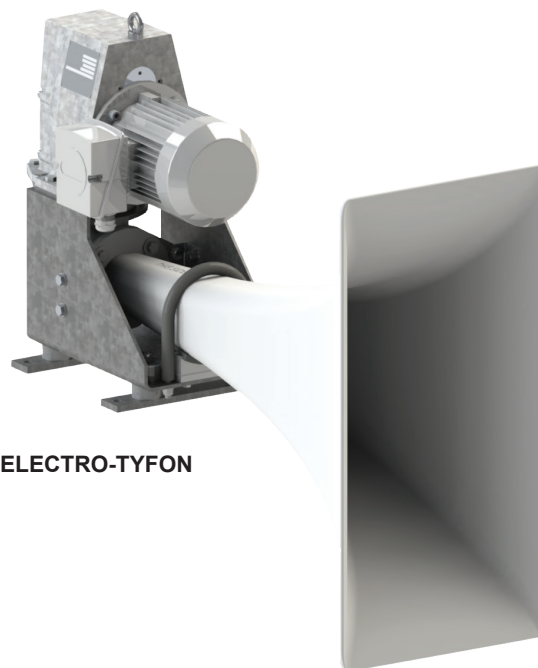

**ELECTRO-TYFON**

## General Information

**ELECTRO-TYFON<sup>®</sup> MT 150/130** is an electrically driven piston ship's whistle. It is built up of comparatively few moving parts as the "swinging piston", no lubricated cylinder and an oil free gearbox.

Important features:

- unsymmetrical sound distribution
- operates in all ambient temperatures without any additional measures
- unaffected by voltage and frequency fluctuations
- oil free, maintenance free and non-corrosive
- easy to install
- complies fully with the International Regulations IMO 1972

## Operates in all temperatures without any additional measures

**ELECTRO-TYFON<sup>®</sup> MT 150/130** will give a high performance in both arctic and tropical climates. A patented system with a high efficiency rectangular horn and a specially designed motor will match the motor speed to the acoustic resonance of the horn at any ambient temperature without any additional measures. This system also prevents the whistle from being affected by voltage and frequency fluctuations in onboard mains.

## Unsymmetrical Sound Distribution

The IMO Regulations stipulate a very high Sound Pressure Level for efficient signaling, yet the sound level of the vessel's own signal at the listening posts shall not exceed 110 dBA.

A common way to solve this "paradox" is to place the whistle very high above deck. But what if the highest point is not high enough? For example: to reduce the noise from the signal by 6 dB, the distance between the listening post and the whistle must be doubled!

**ELECTRO-TYFON<sup>®</sup> MT 150/130** with Unsymmetrical Sound Distribution is the solution. The horn with its unique vertically extended front, and a specially created sound spectrum will reduce the noise on deck with 6–8 dB compared to a conventional whistle with circular orifice.

## Technical Data

Type	Power Supply	Rated current	Ref. No.
MT150/130	3ph440V60Hz(+10%)	11A	24800171
	3ph230V60Hz(+10%)	20A	24800935
	3ph380V50Hz(+10%)	11,5A	24800498
	3ph230V50Hz(+10%)	22A	24800936
	3ph690V60Hz(+10%)	5,5A	24800543
	3ph690V50Hz(+10%)	6 A	24800544
MT150/140	3ph440V60Hz(+10%)	11A	24800569
	3ph380V50Hz(+10%)	20A	24800570
	3ph690V60Hz(+10%)	5,5A	24800571
	3ph690V50Hz(+10%)	6A	24800572

Sound frequency (basic): 130 Hz  
 Sound Pressure Level acc to IMO (1/3 oct band): >138 dB/1m  
 Sound Level A-weighted: 142 dBA/1m  
 Electrical protection class: IP 56  
 Colors:  
     Body Galvanized nat.  
     Motor Grey RAL 7030  
     Horn White RAL 9003  
 Weight (approx.): 68 kg

## Motor Control

Kockum Sonic's Contactor Unit TK 80 is especially developed to control the **ELECTRO-TYFON® MT / MTX series**

Functions:

- Motor start
- Motor overload protection
- Winding heating of motor for anti-condensation purpose.

For full description see data sheet KSM742.

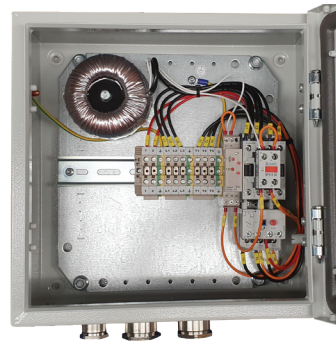

## Dimensions, Installation and Maintenance

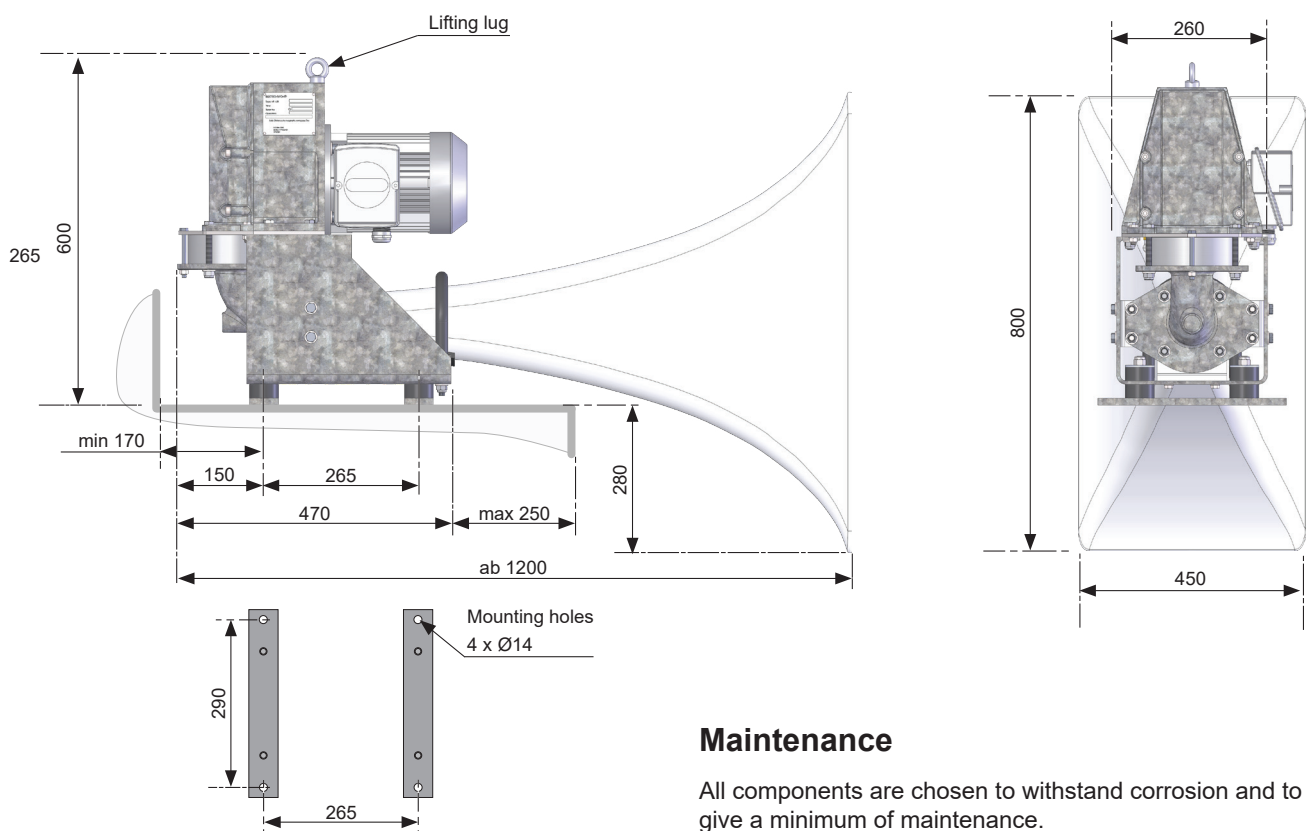

### Installation

**ELECTRO-TYFON® MT 150/130** shall be fixed with four M12 screws that must be firmly tightened and locked.

Mount the whistle on a platform supplied with a safety rail. As the whistle is subject to vibration on starting and stopping, flexible electric cables should be used nearest the motor. The gland on the electric Motor Terminal Box is M 32 for cable Ø 17 - 28 mm.  
Optional: M 25 for cable Ø 9-20 mm.

### Maintenance

All components are chosen to withstand corrosion and to give a minimum of maintenance. The crankcase and foundation is hot galvanized. The motor is marine coated - Marine C4 class. The horn is made of glass fiber armed polyester (white). The cylinder is non lubricated and the gearbox is entirely oil free.

**ELECTRO-TYFON® MT 150/130** is designed to give long reliable service without routine maintenance, but a periodic inspection always gives early warning of any faults that may develop. At least annual inspection is advisable. In very harsh conditions, and high running time, increase frequency accordingly.

See "Inspection, troubleshooting and refurbishing".

# Inspection, Troubleshooting and Refurbishing

## Inspection

The MT/MTX-series Electro-Tyfon is a maintenance free design, but periodic inspection is advisable to get an early indication of faults that might develop.

At least annually, but in conditions with high/very high signaling frequency, increase inspection rate accordingly.

See below instruction:

Remove cover (figure 1 below)

1. Rotate crank shaft / piston rod / piston assembly by the counter weight. It should rotate smoothly, with little friction.
2. Inspect mechanical parts; Piston, counterweight bolts, piston rod lid / screws. Is everything in place and secured?
3. Inspect for grease leakage. Mainly piston rod radial seal, but also crankshaft bearing.

## Troubleshooting

Eliminate possible power failure. Check all 3 phases.

- Low insulation? Check junction box for water ingress. Check motor windings.  
Motor is not running? Check motor windings for interruption, short circuitry (insulation error).
- Motor running but no sound? Check mechanical parts.
- Motor is running but weak sound? If newly installed; Check spec./ mains correlation.  
Check motor windings, all 3 Ok? Check mechanical parts. All parts ok and secured?  
Crank/rod/piston assembly rotating smoothly?
- Abnormal noise, rattling? Inspect mechanical parts, mainly piston / rod. Ok and secured?
- Abnormal vibration? Check dampers. Stud bolts and nuts secured, and damper slightly compressed?  
Check mechanical parts, mainly counter weight.

## Refurbishing / mechanical work

To access some of the refurbishing points, such as piston, piston rod, motor, it's necessary to dismount the "compressor unit".

1. Dismount screws and remove cover.
2. Dismount screws and remove complete "compressor unit". Now you have access to the piston.
3. Dismount piston bolt, counter holding piston rod (to avoid stressing rod bearing), and remove piston.
4. Dismount screw and remove base plate. At this state you have access to the piston rod.
5. Dismount motor bolts and remove motor. At this state you have access to the gearbox, enabling change of crankshaft / gearwheel or bearings, and to the motor, enabling changing motor and/or gearwheel.

It's advisable to replace used locking nuts. All other bolt and screw joints shall be re-secured with locking liquid.

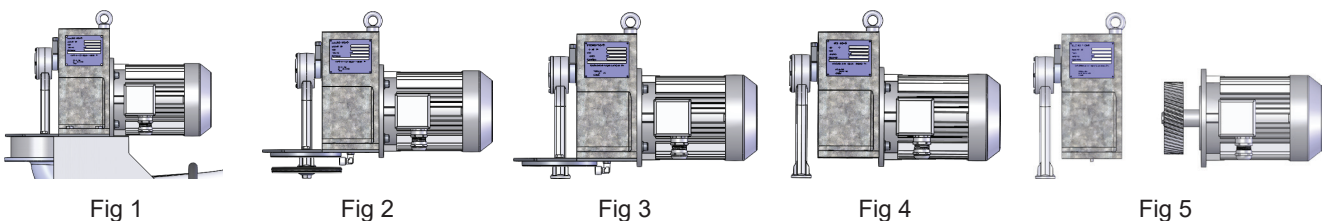

NOTE! Our 380/440V spare motors are as default set to 380/440V.  
If your supply is 230V we could adapt the setting on demand.  
Otherwise, it's easily done by this illustrations.

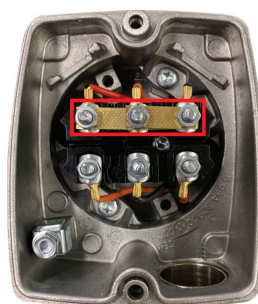

Y - coupling  
(380/440V)

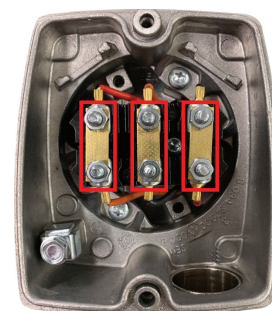

D - coupling  
(230V)

# MT 150/130 - Parts list

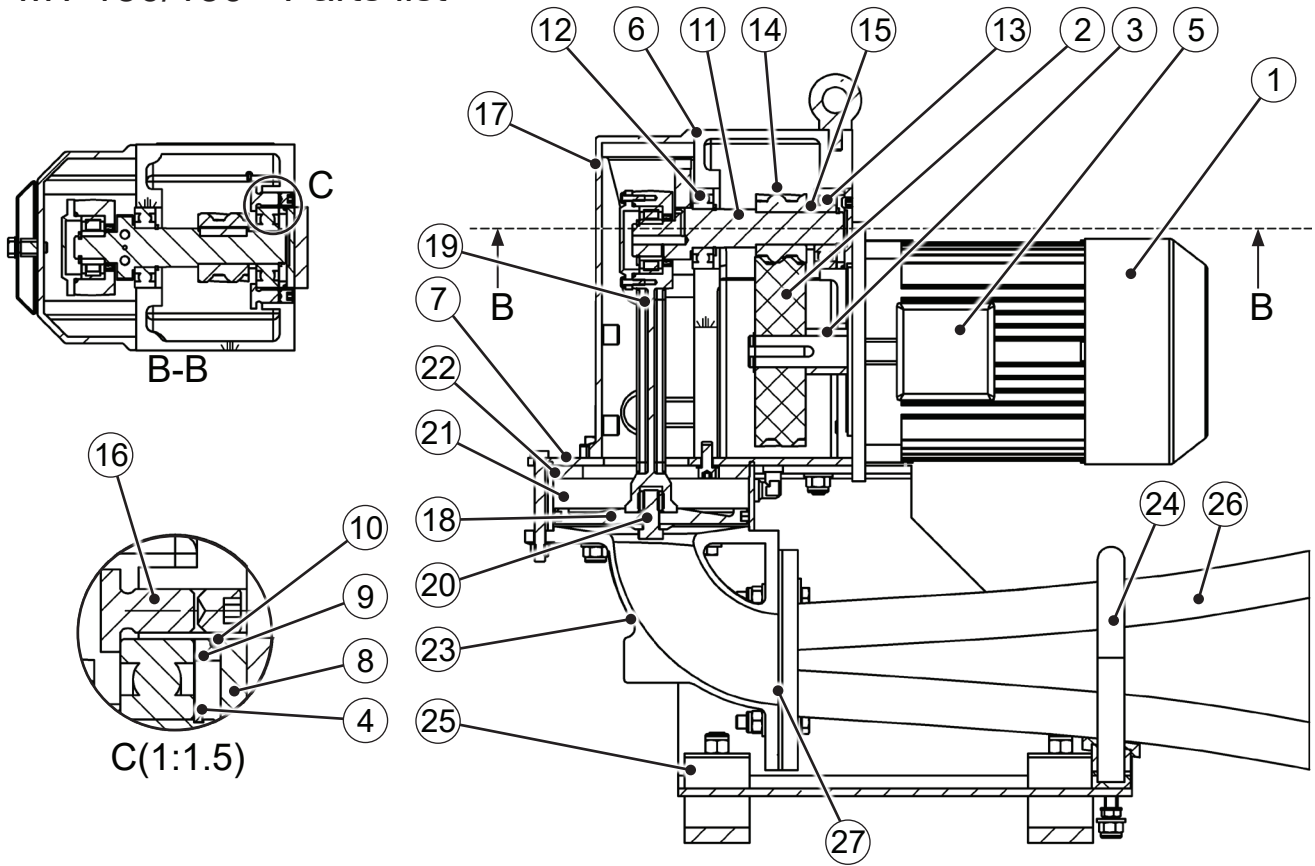

Item	Description	Data/remarks	Ref. No.
1	Motor set	380-440V/50-60Hz Motor, shaft circlip, cable glands, drain Plinth jumpers pre set for Y-config.	24800705
		660-690V/50-60Hz Motor, shaft circlip, cable glands, drain Plinth jumpers pre set for Y-config.	24800706
* 2	Motor gear wheel	60Hz	21768360
		50Hz	21768358
3	Spacer		21768373
4	Circlip	SMS 1581	32470024
5	Connection box	Incl. terminals. Please state Tyfon serial no. for correct revision	
6	Crank case		21769059
7	Base plate		21768365
8	Cap		21768399
9	Spacer		21768404
10	O-ring	57,6 x 2,4	20862066
11	Crank shaft set	Incl. Crankshaft, flat key screws and circlips	24530281
* 12	Bearing rear		20880005
* 13	Bearing front		20880003
14	Gear wheel	60 Hz	21768359
		50 Hz	21768357
15	Spacer		21768376
16	Fixing screw	2 pcs	21769060
17	Cover		21769059
* 18	Piston complete set	Incl piston, rings (x2) , pin	24530296
* 19	Piston rod set	Incl rod, cap, nut, bearing, radial seal, O-ring, screws, washers, circlip	24530291
* 20	Mounting details	Piston / Piston rod MT/MTX	24530297
* 21	Cylinder		21768986
22	Ring		21768368
23	Outlet		21768984
24	Clamp set	Incl clamp, slang, support, spacer, rubberpacking	24530294
25	Vibration damper set	Incl dampers, bushings washers and nuts	24530293
26	Horn		21750123
27	Packing		21765049

\* Spare parts recommended to keep onboard  
Subject to alteration without notice.